

- UL 555 & CAN/ULC-S112 Classified Static Fire Damper, 1½ Hr. Label (File # R25565).
- NFPA 80, 90A & 101 compliant.
- NBC and IBC building codes compliant.

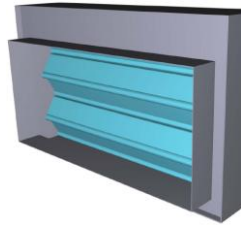

TYPE C

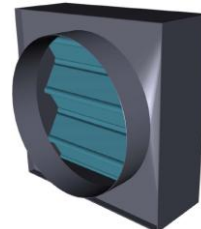

TYPE CR



TYPE CO

STANDARD CONSTRUCTION

DEPTH: 4¼" (108).

FRAME: Roll formed Type 304 Stainless Steel with hemmed edge.

BLADES: Roll formed Type 304 Stainless Steel. Interlocking curtain type blade.

FUSIBLE LINK: 165°F (74 C).

- OPTIONAL CONSTRUCTION**
- Type 316 Stainless Steel Construction.
 - Factory supplied Sleeve (**Required for all multiple section sizes;** collars will be fastened to sleeve ends).
 - 212°F (100 C) Fusible Link.
 - 1½" x 1½" Retaining Angles.

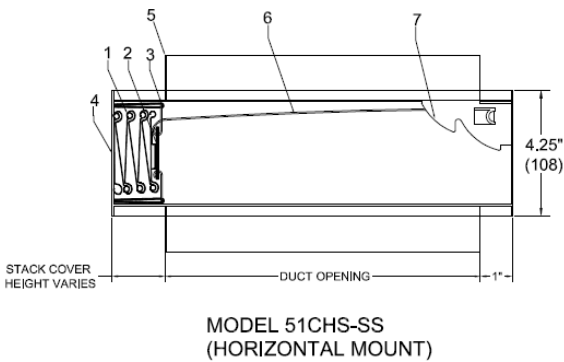
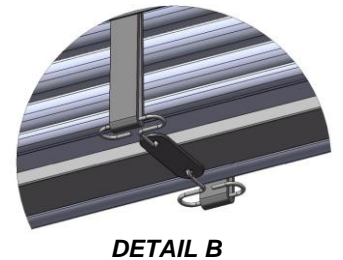
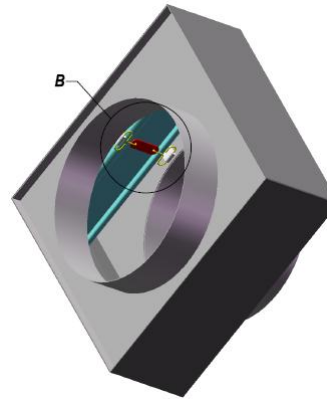
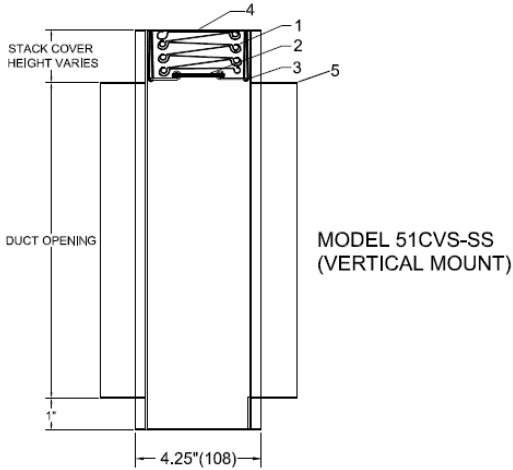

MAINTENANCE RECOMMENDATIONS:

NFPA 80 advises that fire dampers be inspected and tested 1 year after installation, then every 4 years minimum. More frequent inspections may be required due to system use and air conditions, or applicable local codes.

NOTES:

These static dampers are UL/ULC approved for use in HVAC systems where the fans automatically shut down in the event of a fire alarm. 1½ hr. labeled fire dampers are suitable for use in fire separations with a fire resistance rating of 2 hours or less.

Fire dampers must be installed in accordance with manufacturer's instructions. Refer to Alumavent installation instructions for details.

FIRE DAMPER COMPONENTS	
1. S.S. Blades	5. S.S. Duct Connection Collar
2. Fusible Link Assembly	6. S.S. Constant Force Spring
3. S.S. Link Strap	7. S.S. Lock Ramp
4. S.S. Frame	

Dimensions are shown in inches (mm).

TYPE C (SQUARE/RECTANGULAR COLLAR) :

Min. Duct Size: Vertical or Horizontal mount : 4" x 4" (102 x 102).
Max. Duct Size: Single Section
 Vertical mount: 30" x 31"(762 x 787).
 Horizontal mount: 34" x 31" (864 x 787).
Multiple Section (See *NOTE below)
 Vertical mount only: 94" x 67" (2388 x 1702).

TYPE CR (ROUND COLLAR):

Min. Duct Size: Vertical or Horizontal mount: 4" (102) diameter.
Max. Duct Size: Single Section
 Vertical mount: 30" (762) diameter.
 Horizontal mount: 31" (787) diameter.
Multiple Section (See *NOTE below)
 Vertical mount only: 67" (1702) diameter.

TYPE CO (OVAL COLLAR):

Min. Duct Size: Vertical or Horizontal mount: 4" x 3" (102 x 76) oval.
Max. Duct Size: Single Section
 Vertical mount: 30" x 31"(762 x 787) oval.
 Horizontal mount: 34" x 31" (864 x 787) oval.
Multiple Section (see *NOTE below)
 Vertical mount only: 94" x 67" (2388 x 1702) oval.

***NOTE: All multiple section sizes require a factory sleeve. Collars will be fastened to sleeve ends.**

SEE TYPE C STAINLESS STEEL STATIC 1½ HOUR SIZING CHART [SC51CS-SS](#) FOR OVERALL DAMPER DIMENSIONS.

REF. #	QTY.	DUCT SIZE Ø / WxH	MOUNT (V/H)	ACCESSORIES

PROJECT NAME:		ENGINEER:	
CONTRACTOR:		SUBMITTAL DATE:	